



## MS3000

### 装配架



用于垂直安装的组装工作台

- 钢制结构，坚固稳定
- 垂直安装的理想之选
- 可集成于生产线中
- 通过可无级调节的无级中间位置实现符合人体工程学原理的作业
- 通过气缸调节高度
- 装置有钢辊的滚轮支架
- 带塑料滑条的工作台支承面
- 两个可水平移动的型材夹具
- 四路压缩空气接口

选件

- 用于MS 3000的型材倚靠装置可抽出
- 型材夹具可移动
- 螺丝刀支承板
- 行走装置
- 轨道
- 末端止挡
- 用于支承滚轮的型材保护器

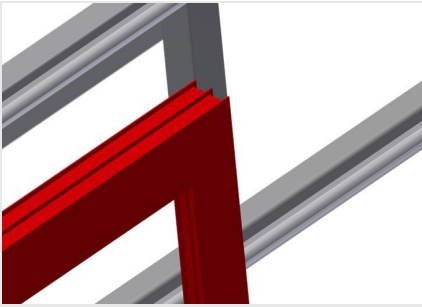

### 支承面

带塑料滑条的工作台支承面

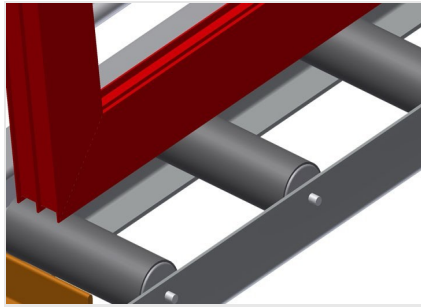

### 滚轮支承装置

带支承滚轮的下部滚道L = 200 mm

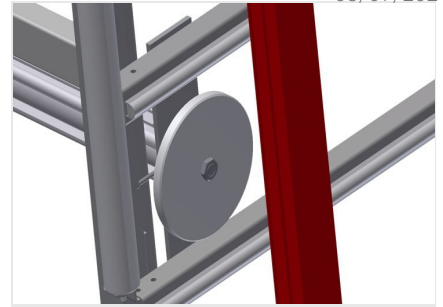

### 夹具

两个侧面材料夹紧装置可在作业时固定型材，型材的夹紧高度最高200 mm



### 高度可调

高度可调，通过调节支脚调节作业高度

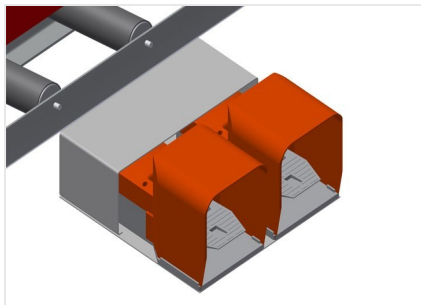

### 脚踏开关

通过脚踏阀门进行控制。在垂直位置上可以气动方式在500 mm的范围内调节高度，气动夹紧

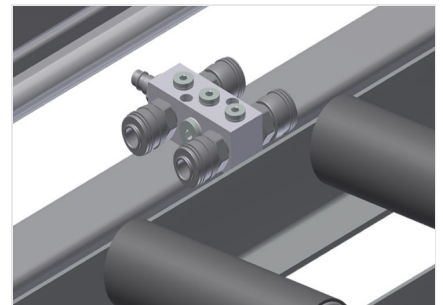

### 四路压缩空气接口

用于气动工具的四路接口





### 型材倚靠装置可抽出

用于MS 3000和MS

4000上部工作台支承面可抽出，工作台支承面可向上抽出800 mm和500 mm，用于较高的框架

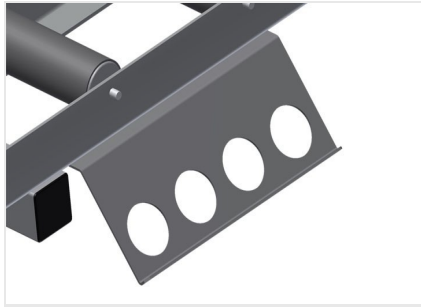

### 螺丝刀支承板

气动工具工具架

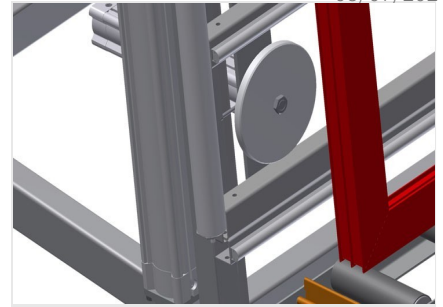

### 型材夹具可移动

辅助夹具确保在作业时的安全固定

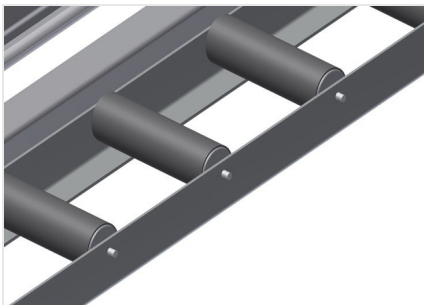

### 用于支承滚轮的型材保护器

用于支承滚轮的型材保护器200 mm (铝/16

x和铝/21 x)，滚道的辊筒带有保护软管，可在窗户元件输入和输出时对其加以保护

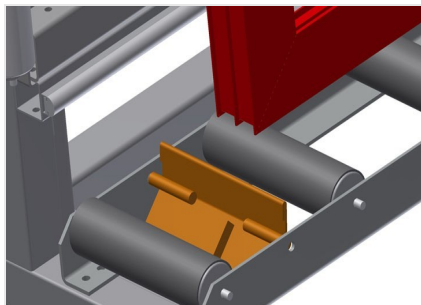

### 末端止挡

末端止挡Rb =200 mm

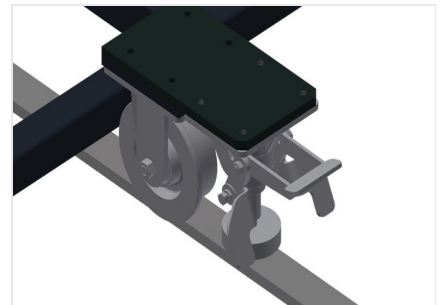

### 行走单元

用于KT/KTH/MS/VE的行走装置，带凸缘滚轮和驻车制动器的行走装置



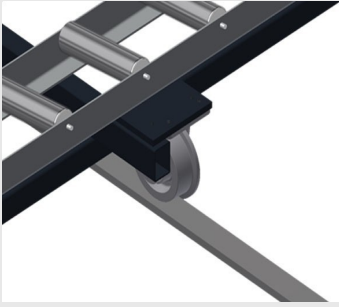

### 轨道

左右两侧轨道各2.0 m



### 装配架MS 3000



### 进料滚辊

滚道始端和滚道末端的保护滚轮







## MS 3000 / □□

- □□3,110 mm
- □□1,200 mm
- □□□□2,050 mm
- □□□□□□□□500 mm
- □□□□200 mm
- □□330 kg
- □□300 kg
- □□□□7□
- □□□□□□□□35 l/min.