



DG 142 XL

DOUBLE MITRE SAW

THE RELIABLE ELUMATEC PRINCIPLE –
“SAWING FROM BELOW”



DOUBLE MITRE SAW DG 142 XL

Up-to-date safety technology, particularly large cutting range, single or multiple cut: The XL version of the popular DG 142 double mitre saw offers everything. The DG 142 XL is the ideal machine for large series production involving 90° and 45° size cutting and is available in four cutting length variants: 3,000 mm, 4,500 mm, 6,000 mm and 7,500 mm. The double mitre saw is supplied as standard with saw blades, safety hoods and the E 190 digital display. The DG 142 XL can be optionally supplemented with a whole range of extras, such as a label printer, a pulsed coolant system and innovative software modules.

- Allows external-dimension cuts for all types of cuts
- Ideal machine for high-volume series production when cutting at 90° and 45°
- Equipped with saw blades and safety hoods as standard
- Equipped with E 190 digital display and handwheel adjustment as standard
- Vertical pneumatic material clamping unit

Cutting length variants

- 3,000 mm
 - 4,500 mm
 - 6,000 mm
 - 7,500 mm
- Additional lengths on request!

Options

- Manual angle adjustment for each unit, digital
- Additional software for E 590: optimisation program, software module for chop and oversize length cuts for E 590 and E 390 as standard
- Label printer for variants with E 390 and E 590
- Mobile workpiece support
- Material clamping units
- Transom stop and lead-cut stop
- Extraction system
- Stationary and/or travelling roller conveyor
- Saw blades
- 5.5 kW motors for aluminium machining
- Hydro feed for aluminium machining
- High-performance cutting fluid for aluminium machining
- Pulsed coolant system for aluminium machining
- Cycling
- Safety fence

Technical specifications

- Minimum cutting length at 90° 400 mm
- Minimum cutting length tilted at 45° 400 mm
- Tilting range inwards 90° – 45°
- For cutting range, see cutting diagram
- Saw blade diameter 550 mm
- Saw blade speed 2,800 rpm
- Power supply 230/400 V, 3~, 50 Hz
- Power output per motor 4 kW
- Compressed air supply 7 bar
- Air consumption per working cycle
40 l without spraying,
64 l with spraying

Controller variants

Manual cutting length adjustment with digital display **E 190**

Positioning control **E 390**

PC control **E 590**

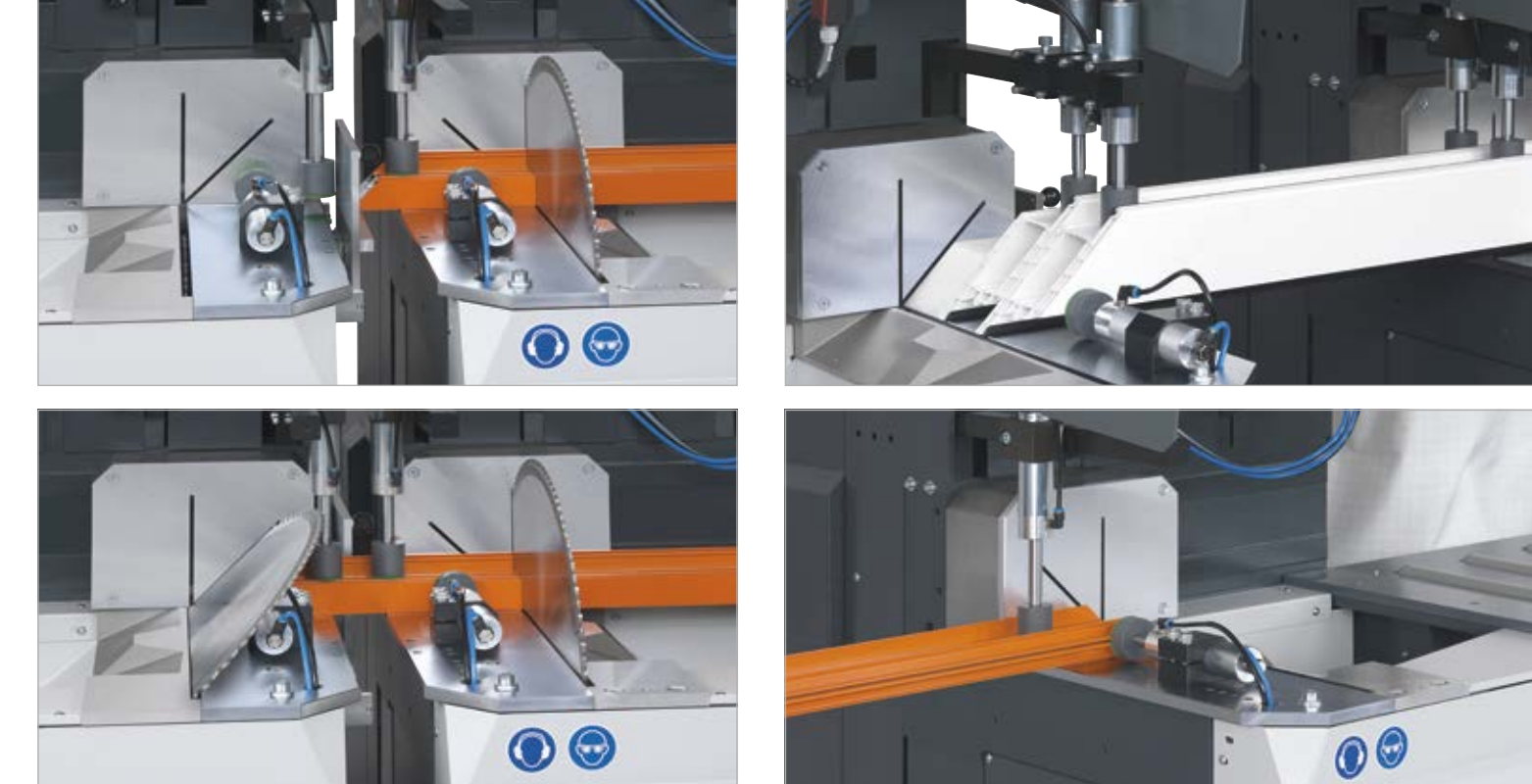

DG 142 XL + PC control E 590 + label printer



PC control E 590 + label printer

Cutting diagrams

Pneumatic clamping device horizontal travel = 80

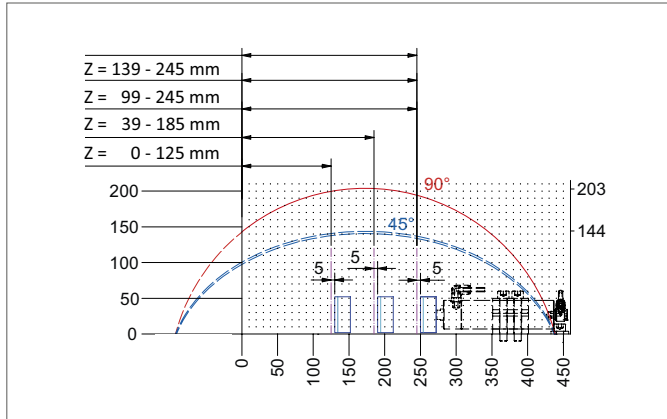

Pneumatic clamping device horizontal travel = 140

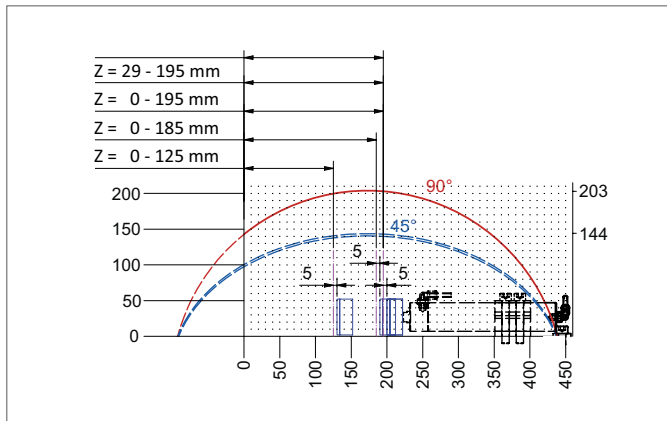

Pneumatic clamping device horizontal travel = 40

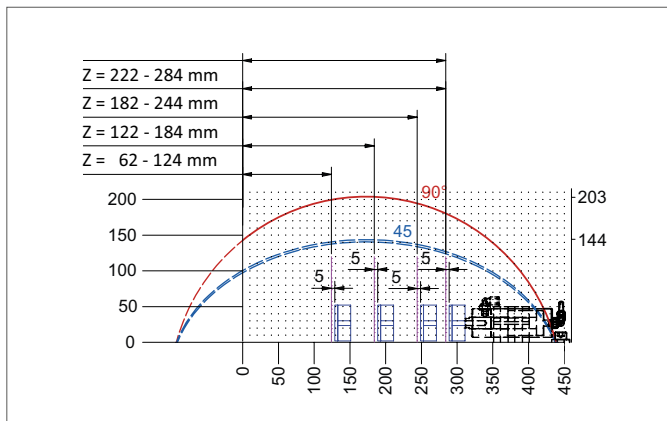

Z = Clamping range

Minimum dimensions

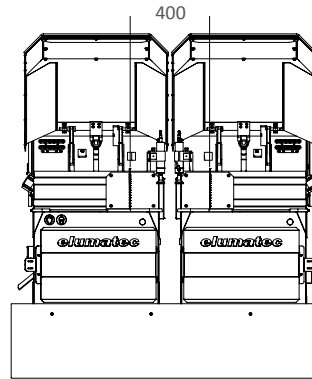

Minimum dimension for 90° cut:
400 mm

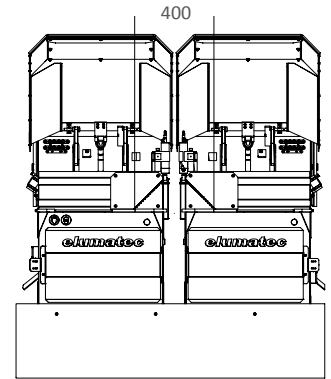

Minimum dimension for 45° cut:
400 mm

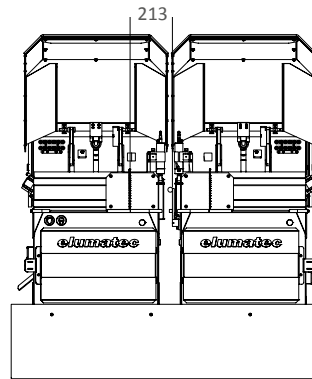

Minimum dimension for 90° cut
with short stroke stop on the
travelling unit: 213 mm

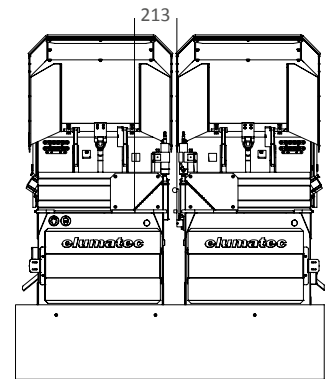

Minimum dimension for 45° cut
with short stroke stop on the
travelling unit: 213 mm

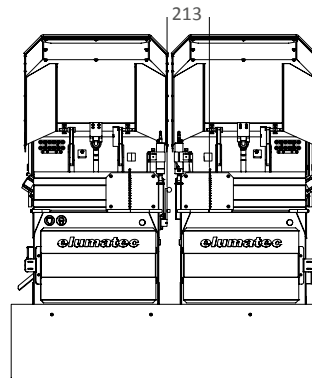

Minimum dimension for 90° cut
with short stroke stop on the
stationary unit: 213 mm

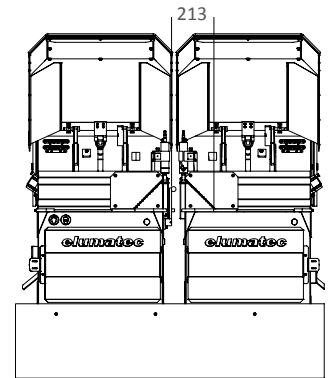

Minimum dimension for 45° cut
with short stroke stop on the
stationary unit: 213 mm



elumatec AG

Pinacher Straße 61
75417 Mühlacker
Germany

Phone +49 7041 14-0
Fax +49 7041 14-280
mail@elumatec.com
www.elumatec.com

