

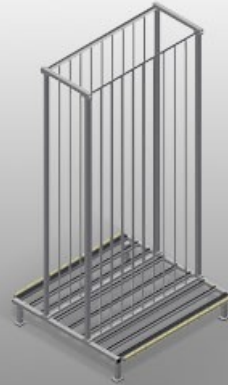

RFR10/02

货架系统



用于存放框架元件的货架

- 钢制结构，坚固稳定
- 用于存放框架的货架
- 每一个元件都可直接取用
- 专门为集成于装配生产线而设计
- 可从两侧取料
- 地板支承面配备塑料滑条
- 带保护软管的隔架分隔杆
- 带滚轮的存放面，装卸简便



框料架RFR 10/02



隔层

所有的支承面均带有防滑PVC涂层，由此可在存放时避免表面发生损坏。

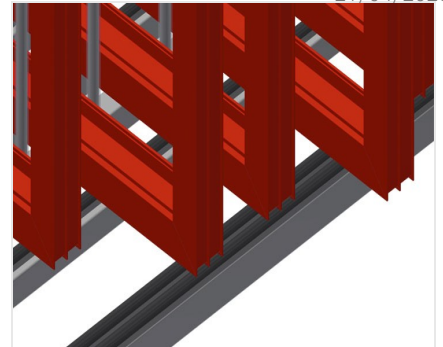

支承面

下部支承面带塑料滑条，保护型材避免损坏

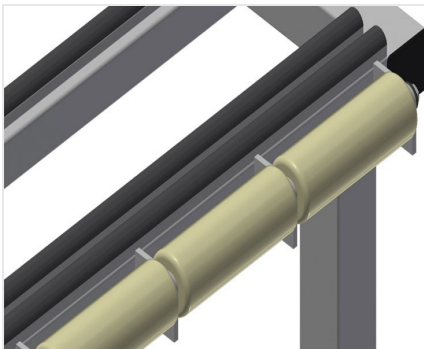

滚轮

每个隔层均配备有方便装卸重型和大型元件的滚轮。





- □1,950 mm
- □1,620 mm
- □3,375 mm
- □□□160 mm
- □□□3,010 mm
- □275 kg
- 800 kg

