



### AKS134/00

#### NOTCHING SAWS



- Variable notching possibilities for mullion and transom combinations, e.g. for curtain walls, conservatories, sky lights, and special designs
- Precise and safe notching is ensured because the workpiece is fixed and only the saw units move
- Both saw units are adjusted in height simultaneously by means of a hand wheel (analogue display on the hand wheel)
- The cutting depth is set using an analogue display
- Manual angle adjustment of the saw blades using a digital display of the tilting angles
- Support table with compound slide and pivoting back fence is manually adjustable for optimal use of the cutting range
- The angle of the pivoting back fence is shown on a digital display
- Horizontal and vertical profile clamping
- Automatic working cycle at a 90° pivoting angle (two-hand control when cutting special angles)
- Hydro-pneumatic saw feed

#### **NOTCHING SAW AKS 134/10**

See AKS 134/00, however:

- Equipped with a 4-axis controller for automatic adjustment of the horizontal and vertical saw blades for angle cutting, as well as for height adjustment and notching depth
- Values from design drawings can be entered directly via the keyboard

#### **Options**

- Laser indicator for cutting line
- Noise protection package
- Saw blades
- High performance cutting fluid



**Notching saw AKS 134/00**

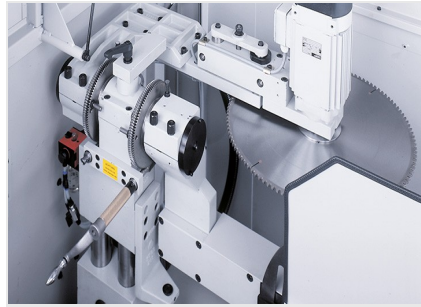

**Notching saw AKS 134/00**

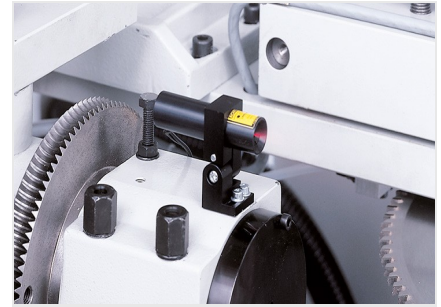

**Notching saw AKS 134/00**

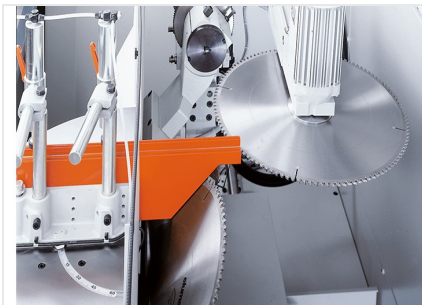

**Notching saw AKS 134/00**

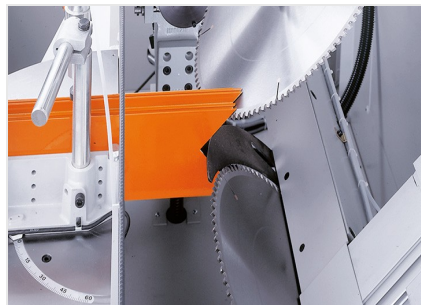

**Notching saw AKS 134/00**

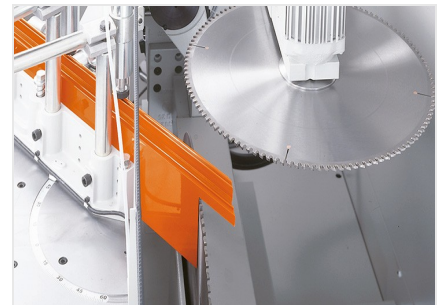

**Notching saw AKS 134/00**





### AKS 134/00 / NOTCHING SAWS

---

Lower saw unit (vertical):

- Saw blade diameter 550 mm
- Tilting range from 45° forwards to 60° towards the rear
- Max. cutting height of 210 mm
- Power supply 230/400 V, 3~, 50 Hz
- Power output 3 kW with motor brake
- Saw blade speed 2,800 rpm
- Manual tilting angle adjustment with digital display (standard)

Upper saw unit (horizontal):

- Saw blade diameter 500 mm
- Tilting range from 55° downwards up to 60° upwards
- Notching depth, max. 190 mm
- Power supply 230/400 V, 3~, 50 Hz
- Power output 3 kW with motor brake
- Saw blade speed 2,800 rpm
- Manual tilting angle adjustment with digital display (standard)
- Travel 830 mm max.

Support table with working height of 990 mm:

- Pivoting range from 30° left to 30° right, home position 0°
- Pivoting range manual with digital display
- Compressed air supply 7 bar
- Air consumption per working cycle 35 l without spraying, 45 l with spraying
- Length 3,000 mm, depth 1,420 mm, height 1,600 mm, weight 1,250 kg