

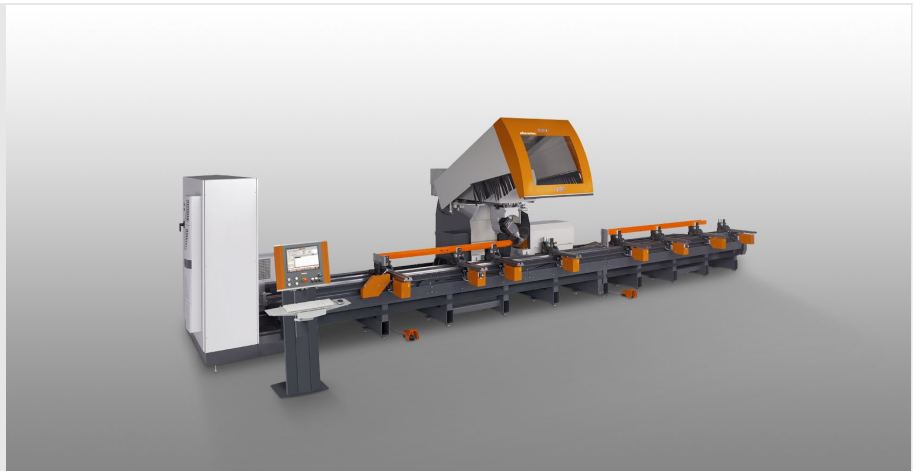

SBZ150

Machining Centres



- 5-axis profile machining centre
- Designed for economical and efficient machining of aluminium and thin-walled steel profiles
- All operations, such as routing, drilling, tapping, thread milling, notching and sawing, are performed while the profile bar is stationary to protect the profile surfaces
- 6-sided machining. From below with an angle head (option)
- Operator software with graphic 3D display of workpieces
- The magazine can be equipped with nine standard tools, five special tools (angle routing head and and special cutters) and one saw blade
- Robust, low-wear direct drives on all axes allow rapid home positioning of the machining assembly
- Automatic clamp recognition and clamp positioning
- Two separate working zones enable machining in shuttle operation
- 5-axis controller for 3D machining, 15" colour display, USB ports, and network connection
- Windows operating system
- eluCam

Machining lengths

SBZ 150 – 6.0 m

- Max. machining length with profile end machining, 5,900 mm
- Max. machining length without profile end machining, 6,220 mm

SBZ 150 – 7.3 m

- Max. machining length with profile end machining, 7,200 mm
- Max. machining length without profile end machining, 7,520 mm

SBZ 150 – 9.0 m

- Max. machining length with profile end machining, 8,900 mm
- Max. machining length without profile end machining, 9,220 mm

SBZ 150 – 10.3 m

- Max. machining length with profile end machining, 10,200 mm
- Max. machining length without profile end machining, 10,520 mm



- SBZ 150 - 12.0 m
- Max. machining length with profile end machining, 11,900 mm
- Max. machining length without profile end machining, 12,220 mm

Options

- Shuttle operation for working on two sides
- Angle routing head for machining from below
- Automatic length measurement
- Chips conveyor belt
- Barcode scanner
- Label printer
- Clock system
- Tool holders
- Collet chuck
- Collets
- Saw blades
- Tools
- eluCad (office software package for optimized production management)



**Profile machining centre
SBZ 150 eluCam**

SBZ 150 + special accessories



**Profile machining centre
SBZ 150 eluCam**

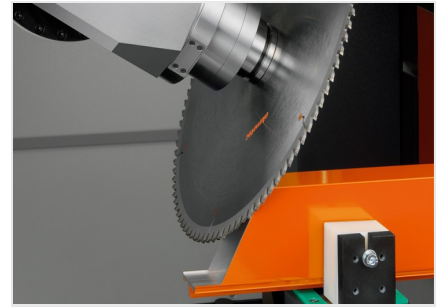

**Profile machining centre
SBZ 150 eluCam**

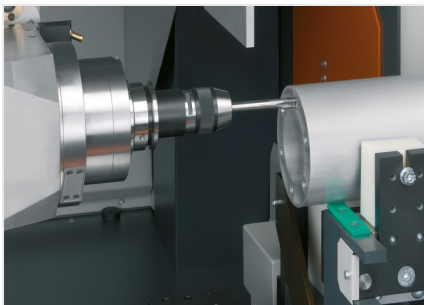

**Profile machining centre
SBZ 150 eluCam**

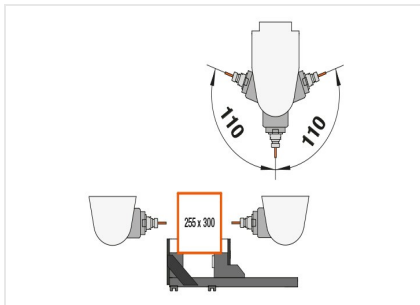

**Profile machining centre
SBZ 150 eluCam**



**Profile machining centre
SBZ 150 eluCam**



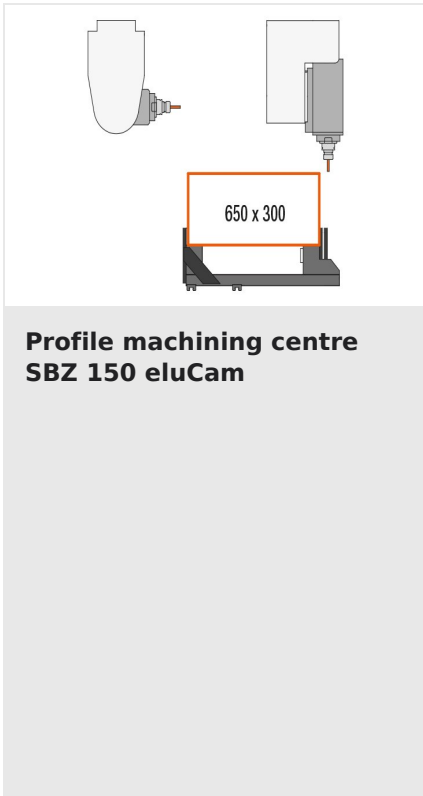

**Profile machining centre
SBZ 150 eluCam**





SBZ 150 / MACHINING CENTRES

- Traverse path X-axis, 6,500 mm, 7,800 mm, 9,500 mm, 10,800 mm, 12,500 mm (additional lengths on request) Vmax. 70 m/min.
- Y-axis traverse path 1,000 mm, Vmax. 40 m/min.
- Z-axis traverse path 630 mm, Vmax. 40 m/min.
- A-axis pivoting angle: +/-110°, user programmable in 1/10° steps
- C-axis pivoting angle: +/-182°, user programmable in 1/10° steps
- Max. spindle speed 24,000 rpm
- Spindle power output 15 kW S1
- Cutting tool diameter 100 mm max.
- Disc milling cutter diameter of max. 100 mm
- Saw blade diameter up to 400 mm max.
- Tool holder HSK-63F
- Compressed air supply 7 bar
- Power supply 400 V, 3~, 50 Hz, 80 A
- Air consumption per minute, 200 l with spraying
-