



SBZ131

Machining Centres



- 3-axis profile machining centre
- Designed for economical and efficient machining of aluminium, steel and stainless steel profiles
- All operations, such as routing, drilling and tapping, are performed while the profile bar is stationary to protect the profile surfaces
- The on-board turret head ensures that tool changing times are kept very short, thereby optimizing machining cycles
- The turret head can be equipped with eight tools or four angle routing heads
- Autonomous clamp positioning enables clamp arrangement during secondary time
- 3-axis controller
- The tool spindle is designed as an additional axis
- Angle heads for lateral and profile end machining
- 18.5" panel PC, USB ports and network connection
- Windows operating system
- eluCam

Machining lengths

SBZ 131 - 4.2 m

- Max. machining length with profile end machining, 4,080 mm
- Max. machining length without profile end machining, 4,200 mm

SBZ 131 - 7.2 m

- Max. machining length with profile end machining, 7,080 mm
- Max. machining length without profile end machining, 7,200 mm

SBZ 131 - 8.5 m

- Max. machining length with profile end machining, 8,380 mm
- Max. machining length without profile end machining, 8,500 mm

SBZ 131 - 10.2 m

- Max. processing length with profile end machining, 10,080 mm
- Max. processing length without profile end machining, 10,200 mm

SBZ 131 - 11.5 m

- Max. machining length with profile end machining, 11,380 mm
- Max. machining length without profile end machining, 11,500 mm





Options

- Two separate working zones enable machining in shuttle operation. There is also a central laser scanner on the operator's side to protect the area for maximum safety.
- Cycling program with special clamping device and outfeed conveyor
- Automatic length measurement
- Angle routing heads
- High-speed spindle
- Slow spindle
- Saw head
- Clamping unit accommodates double profile machining
- Barcode scanner
- Tool holders
- Collet chucks
- Collets
- Tools
- eluCad (office software package for optimised production management)



Profile machining centre SBZ 131 eluCam

SBZ 131 + special accessories

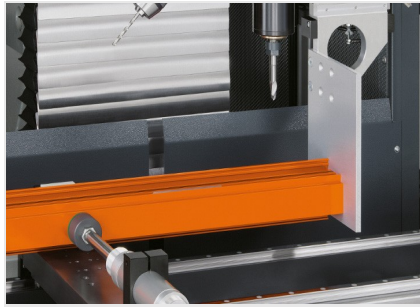

Profile machining centre SBZ 131 eluCam

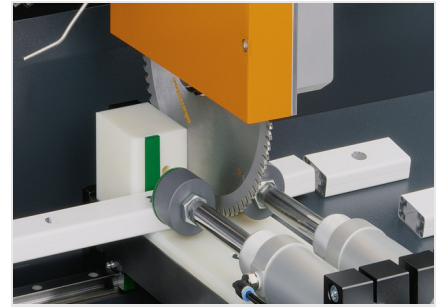

Profile machining centre SBZ 131 eluCam

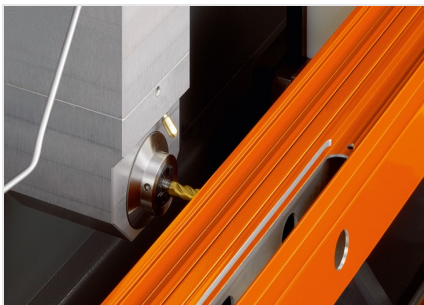

Profile machining centre SBZ 131 eluCam

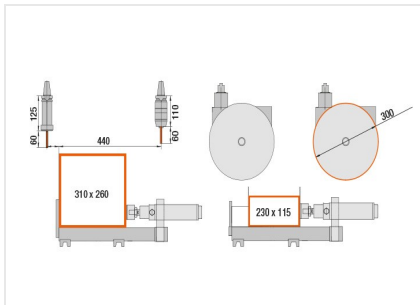

Profile machining centre SBZ 131 eluCam

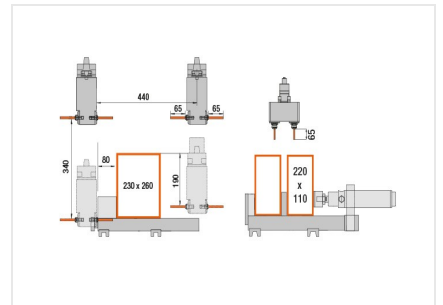

Profile machining centre SBZ 131 eluCam



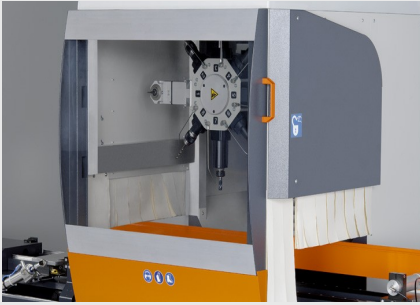

**a-Profile machining
centre SBZ 131 eluCam**

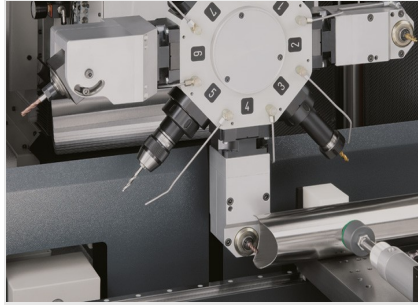

**Profile machining centre
SBZ 131 eluCam**

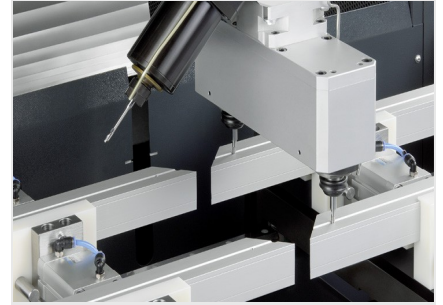

**Profile machining centre
SBZ 131 eluCam**

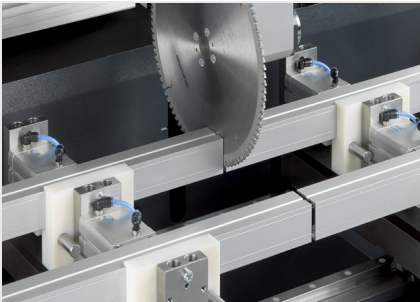

**Profile machining centre
SBZ 131 eluCam**

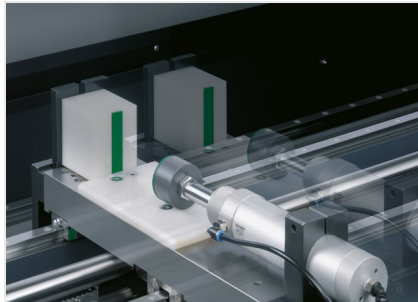

**Profile machining centre
SBZ 131 eluCam**





SBZ 131 / MACHINING CENTRES

- Traverse path X-axis, 4,200 mm, 7,200 mm, 8,500 mm, 10,200 mm, 11,500 mm (additional lengths on request) Vmax. 60 m/min.
- Traverse path Y-axis, 485 mm, Vmax. 60 m/min.
- Traverse path Z-axis, 340 mm, Vmax. 60 m/min.
- Max. spindle speed 6,000 rpm, 18,000 rpm with high-speed spindle
- Autonomous clamp positioning with 700 mm of travel
- Spindle power output 5.5 kW
- Tool changer for eight tools on a turret head
- Compressed air supply 7 bar
- Power supply 400 V, 3~, 50 Hz, 63 A
- Air consumption per minute 100 l with spraying