

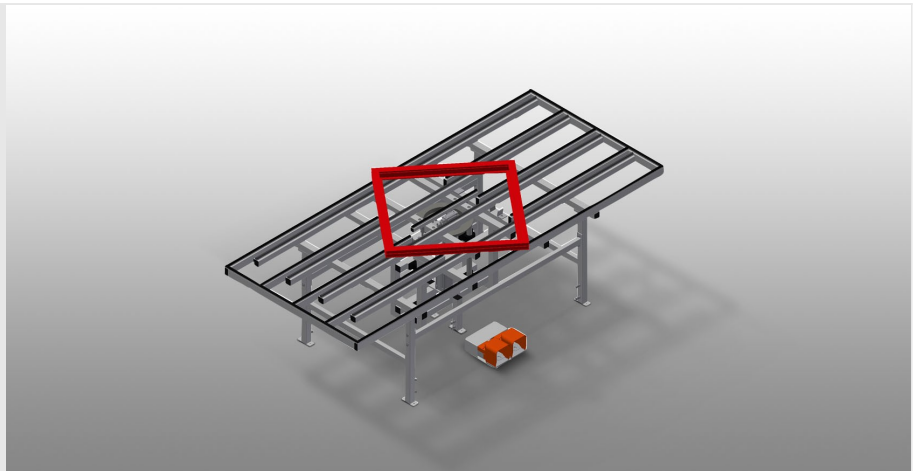

HD3000

LIFT AND TURN TABLES



Lift and turn table for assembly and gasket insertion

- Stable steel construction
- Ideal for assembly and gasket insertion
- Adjustable height
- Inner table height pneumatically adjustable
- Inner table can be rotated; with pneumatic fixing brake
- Inner table equipped with rubber strips
- Outer table with plastic slide bars
- 4-fold compressed air supply

Option

- Outer table also available with rubber profiles on request (for aluminium profiles)

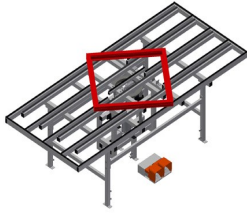

Lift and turn table HD 3000

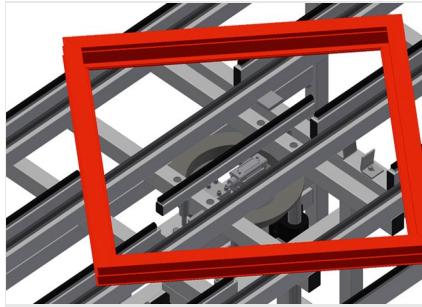

Lift and turn mechanism

Practical for hardware assembly as well as for final assembly and gasket insertion. Inner table height pneumatically adjustable. Inner table can be rotated; with pneumatic fixing brake

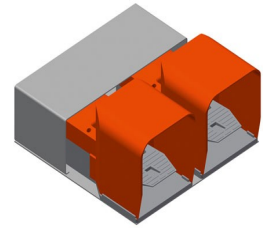

Foot switch

Control via foot valve

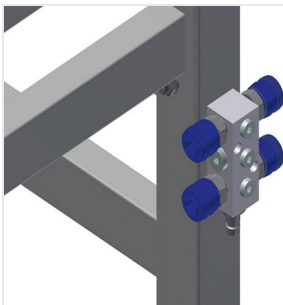

4-fold compressed air connection

4-fold compressed air connection for connecting compressed-air tools



Outer table with rubber strips

Outer table rubber-knob profile for HD 3000. Outer table also available with rubber strips on request.

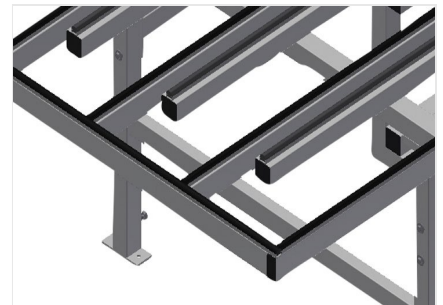

Supporting surfaces

Outer table with plastic slide bars. Inner table equipped with rubber strips.





HD 3000 / LIFT AND TURN TABLES

- Length 3,000 mm
- Weight 240 kg
- Width 1,300 mm
- Load 200 kg
- Adjustable height 850 - 1,000 mm
- Compressed air supply 7 bar
- Travel of pneum. inner table 150 mm
- Air consumption approx. 35 l/min.